

TRANSMISSION WIRE

COMPONENTS

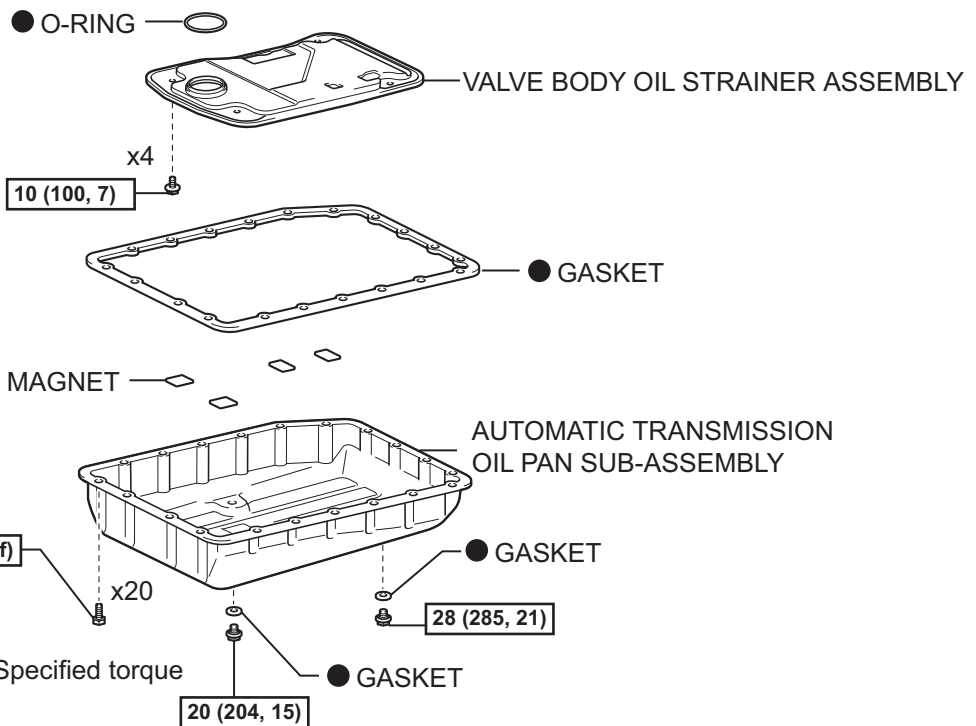
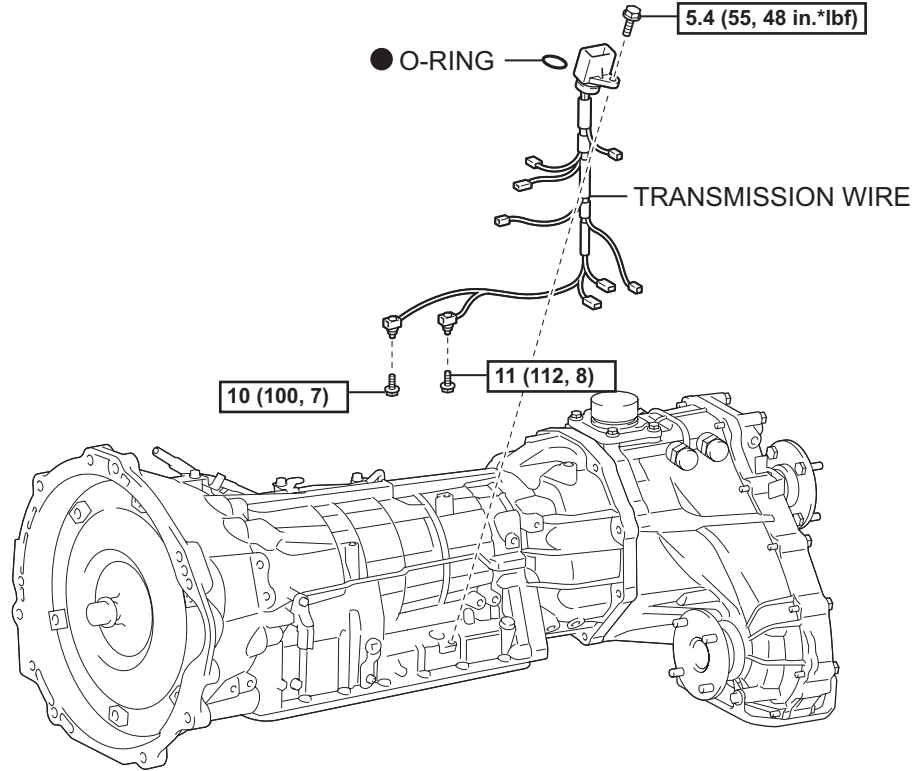

N*m (kgf*cm, ft*lbf) : Specified torque

● Non-reusable part

AT

REMOVAL

1. **DISCONNECT CABLE FROM NEGATIVE BATTERY TERMINAL**
2. **DRAIN AUTOMATIC TRANSMISSION FLUID**
 - (a) Remove the drain plug and gasket, and drain ATF.
 - (b) Install a new gasket and the drain plug.
Torque: 28 N*m (285 kgf*cm, 21 ft.*lbf)

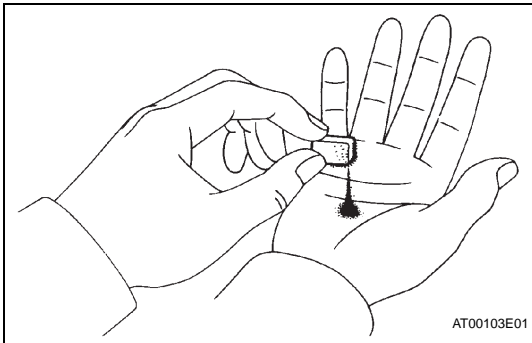
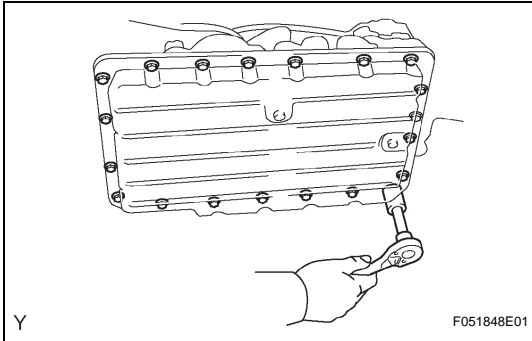

3. **REMOVE AUTOMATIC TRANSMISSION OIL PAN SUB-ASSEMBLY**

NOTICE:

Some fluid will remain in the oil pan.

- (a) Remove the 20 bolts and the oil pan.

- (b) Examine the particles in the pan.

- (1) Remove the magnets and use them to collect steel particles. Carefully inspect the foreign matter and particles in the pan and on the magnets to anticipate the type of wear you will find in the transmission.

Steel (magnetic): bearing, gear and clutch plate wear

Brass (non-magnetic): bushing wear

4. **REMOVE VALVE BODY OIL STRAINER ASSEMBLY**

- (a) Remove the 4 bolts and the oil strainer.

NOTICE:

Be careful as some fluid will come out of the oil strainer.

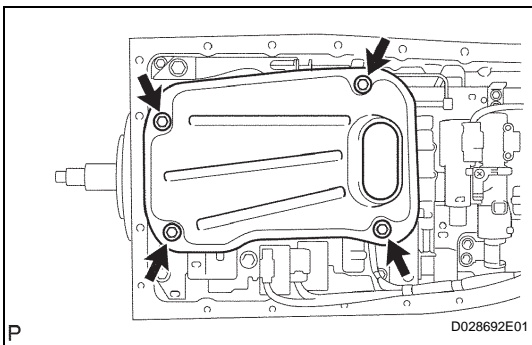

5. **SEPARATE TRANSMISSION WIRE**

- (a) Remove the 2 bolts and 2 clamps.
- (b) Disconnect the ATF temperature sensor.
- (c) Disconnect the 7 connectors from the solenoid valves.

